

Inventronics Design-in Guide

Choosing and Configuring 0-10V/PWM/Timer Programmable Outdoor LED Drivers

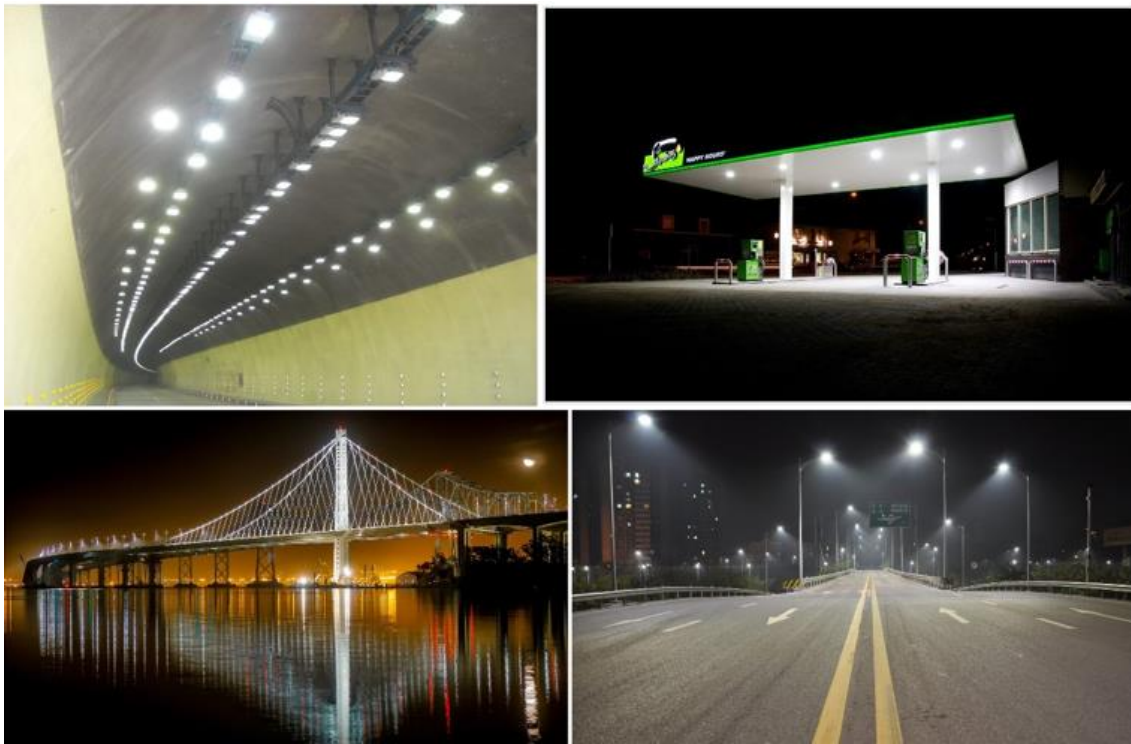

INVENTRONICS
DRIVING THE LIGHTING REVOLUTION

Content

Introduction	3
Part Numbering Scheme	4
Features Brief	5
Programmable Functions	5
Output Current	5
Dimming	5
External Over Temperature Protection	5
12V Auxiliary	5
High Surge Protection	5
High Lifetime and Reliability	6
Limited Inrush	6
Certifications and Ratings	6
Water Resistant	6
Electrical Design-in Review	6
Defining Output Characteristics	6
Defining Application Requirements to Select the Best LED Driver Family	7
Understanding the I-V Operating Area of Constant Power Drivers	8
Good Performance Area	9
Allowed and Programmed Operating Area	9
Programming	11
Connections for Programming	11
Opening the Inventronics Software Interface	12
Changing the Output Current and Resulting Optimized Output Voltage Range	13
Selectable Dimming Methods	14
0~10V and 0~5V Dimming	14
PWM Dimming	15
Timer Dimming Modes	17

Implementing External Over Temperature Protection	22
Writing to Driver and Saving Configuration Files ...	23



Introduction

This guide will explain the behavior of the Inventronics programmable drivers and how to utilize features within the programming interface. These instructions apply to the programmable drivers with built-in 0-10V, PWM, and Timer dimming capabilities. We also offer a full line of DALI programmable drivers that are discussed in the *Design in Guide for DALI Outdoor Programmable LED Drivers*.

The traditional LED switched-mode power supply is made of analog components and is designed to regulate the electrical output. This output will either have a constant current output (CC driver) or a constant voltage output (CV driver). The type chosen and the driver model should be selected based upon the output current and output voltage required for the application. For some applications, the output needs to be adjusted slightly in order to reach the assessment standard of luminous flux, or efficiency,

which can vary between different LEDs. This can complicate product inventory requirements and, at times, the design process. Inventronics programmable LED drivers were created as a solution to help simplify these complications by offering an adjustable current output. As the current is lowered, the possible power output is not derated, but instead the voltage increases. The output performance will be explained in more detail within this guide.

In addition to simplifying LED driver sourcing and selection, the programmable drivers have also been enhanced with many features to best fit a wide variety of applications and to support future-proofing luminaires. These features include:

- 0-10V dimming, PWM dimming, and built-in timer dimming options
- Output Lumen Compensation (OLC) that can double as an end of life indicator
- External temperature sensing
- 12V auxiliary supply that sources either 20mA or 200mA
- High surge protection
- Increased lifetime
- High efficiency
- Global certifications with ratings for IP67, UL Wet and independent use

Part Numbering Scheme

Inventronics has more than 1900 different model numbers that can be distinguished by the assigned part numbering scheme. The examples in **Figure 1**, **Figure 2**, and **Figure 3**, will show only the options that are relative to the outdoor 0-10V, PWM, Timer dimmable programmable drivers. **For more information on other products, please contact your local sales representative.**

The three letter prefix defines if it is an indoor or outdoor product, what the input voltage range is, and what type of driver it is. See **Figure 1**.

The next three numbers indicate the maximum rated output power. The single letter indicates how many independently regulated output channels there are – currently Inventronics only offers single channel programmable drivers. The next three numbers show what the maximum programmed output current is for the model. See **Figure 2**.

The three-letter suffix defines the type of dimming, the type of cabling, and any additional application features. This is followed by four additional characters that represent a customization; however, standard parts are simply followed by “0000” which is not shown on the face of the label. See **Figure 3**.

Using the part numbering scheme, the following can be determined about the EUD-096S350DTA driver:

- Outdoor
- Universal Input
- 96W Maximum Output Power
- Single Channel
- 3.5A Maximum Programmable Output Current
- 0-10V | PWM | Timer Dimming Capable
- UL Cabling
- New Enhanced Outdoor Features
- Standard

Series		1 Alpha Character
E	Outdoor LED Driver	
L	Indoor LED Driver	

Input Range		1 Alpha Character
U	90-305Vac	
D	140-305Vac	
B	176-305Vac	
F	180-528Vac	
S	249-528Vac	

Type		1 Alpha Character
D	Full Feature Programmable	
G	General Purpose Programmable	
K	Programmable or Vertical installation type	
R	Round Shape Design with AOC Function	
S	Short Case with Push Terminals	
P	Adjustable Output Current with Dip-switch	

Figure 1: Part Numbering Scheme Prefix

Output Power		3 Numeric Characters
600	600W	
150	150W	
096	96W	
075	75W	

No. of Outputs		1 Alpha Character
S	Single	
D	Dual	

Output Current		3 Numeric Characters
980	9800mA	
350	3500mA	
105	1050mA	
070	700mA	

Figure 2: Part Numbering Scheme Power + Current

D T A X X X X		Modify	2 Alpha Character
		00	Standard Product

Case & Application Feature		1 Alpha Character
A	Second Generation for Outdoor Products	
Y	Outdoor/Indoor Extremely Cold Application down to -55°C	
F	Indoor Long and Slim Metal Case	
E	Outdoor/Indoor Terminal Block	
R	Indoor Round Case	
L	Outdoor/Indoor Long Lifetime	

Input Cable Indicator		1 Alpha Character
S	Standard, 2 Pin, UL	
T	Standard, 3 Pin, UL	
D	Standard, 2 Pin, VDE	
V	Standard, 3 Pin, VDE	

Options & Modes		1 Alpha Character
S	Non-Dimming Control	
D	0-10V with/without 0-5V/PWM/10V PWM/Timer	
T	Timer Dimming	
B	DALI with/without PWM/10V PWM/AC Dim/Timer	

Figure 3: Part Numbering Scheme Suffix

Features Brief

Inventronics is dedicated to designing LED drivers that best support customer needs in a wide variety of applications. The programmable LED drivers offer many features to help realize this goal.

Programmable Functions

Each of the following functions are easily programmed via the Inventronics programming software interface.

Output Current

The output current can be programmed to any current in the specified programming region. The full rated output power of the driver is maintained even when lowering the output current. The output power starts to de-rate as the current is set < 70% of the maximum rated output current for the model. The actual programmed value will round to the closest 1% of the maximum rated output current.

Dimming

There are three different selectable dimming methods in addition to output lumen compensation. The dimming range is most commonly 10%-100% with dim-to-off supported in certain families.

0-10V

0-10V dimming is the default setting and most commonly used. 0-5V dimming is also offered in certain families.

PWM

PWM dimming can be selected with either positive or negative logic.

Timer

Three different timer modes exist. Traditional, Self Adapt-MidNight, and Self Adapt-Percentage all function as counters that start when the driver is turned on.

Output Lumen Compensation + End of Life Indicator

Output lumen compensation behavior can be defined by specifying the total percentage output desired at any given kilo hour of operation to help counter reduced LED efficacy over time. The total time of operation can also be read from the driver. If desirable, this feature can be used as an end of life indicator by reducing the output current at a specified time.

External Over Temperature Protection

A Negative Temperature Coefficient (NTC) thermistor may be added to any desired location in a luminaire design for added protection against excessive heat. The trigger temperature, recovery temperature, and driver behavior during these events are all easily set in the Inventronics programming software interface.

12V Auxiliary

Each driver has a 12V auxiliary line for powering external devices. This feature helps future-proof luminaires and is available in 20mA and 200mA. The 200mA versions are optimized for wireless solutions and dim-to-off. This eliminates the need for relays within controllers and external power packs which reduces overall costs while also simplifying the installation.

High Surge Protection

High level surge protection is integrated in every design. Typically, this is offered in 6kV differential mode (line to line) and 10kV common mode (line to earth) to meet IEC 61000-4-5, but may vary by product family.

High Lifetime and Reliability

Choosing an LED driver with high lifetime and reliability is important as drivers are a critical component of any luminaire design. For reference, the EUD-096SxxxDxA family has a typical lifetime of 104,000 hours with a case temperature of 70°C. Along with high lifetime is a warranty to stand behind the product. Most Inventronics programmable drivers offer a 7-year warranty limited only by the operating specifications in the datasheet.

Limited Inrush

Inrush current affects the selection of circuit breakers, fuses, and AC powered controls. Inrush current is limited upon start-up and the waveform form is published in every datasheet along with the worst-case I²T value for the specified series.

Certifications and Ratings

Inventronics understands the requirements and restrictions placed upon the global market. Safety labs for UL, TUV, and CB are all operated in-house for expedited testing and drivers have obtained ATEX, BIS, CB, CCC, CE, CQC, EAC, EMF, ENEC, FCC, Global Mark, KC, KS, PSE, SAA, TUV, and UL (Type HL, Type TL, Class P) certifications. All products are RoHS compliant.

Water Resistant

To help simplify luminaire design, the outdoor drivers are typically IP 67, rated for Independent use, and are approved for UL Wet location use.

Electrical Design-in Review

LED loads are often customized and the desired lighting effect and requirements vary by application. With this, selecting an appropriate LED driver is more involved than selecting a traditional fluorescent ballast. Several considerations need to be made when selecting the best LED driver for an application.

Defining Output Characteristics

The primary role of a CC LED driver is to regulate the output current going through the LEDs. With this, the required electrical output characteristics should first be defined. This includes:

- Maximum forward voltage of the assembled LED load (V_f)
- Required output current going through the assembled LED load (I_o)

From this, the maximum output power required (P_{outmax}) and consequently the minimum rated output power of the driver can be defined by multiplying the maximum forward voltage by the output current.

$$P_{outmax} = V_{fmax} \times I_o$$

Example 1: assume a load has two LED boards with a maximum forward voltage of 32V optimized for 1400mA. When connecting these boards in parallel, the maximum forward voltage remains at 32V while the required output current doubles to 2800mA.

$$32V \times 2.8A = 89.6W$$

Example 2: if connecting the same boards in series, the maximum forward voltage doubles to 64V and the required output current remains at 1400mA.

$$64V \times 1.4A = 89.6W$$

Notice in each configuration, the output power is the same, so a driver rated to output at least 90W is required. Also, notice that the required output current and voltage is different. These differences explain why many different models exist in each series and knowing these parameters will determine which model in a family is best.

Defining Application Requirements to Select the Best LED Driver Family

After defining the power level, application conditions should be defined:

- Input voltage range
- Luminaire shape
- Ambient operating temperature
- Certifications
- Primary design objective
 - Wireless controls ready
 - Lowest possible cost
 - Longest lifetime
 - etc.

With the required output power and application conditions, the best LED driver family may be selected.

Continuing with **Example 1** and **Example 2**, if the application requires 120~277Vac input, no specific shape, -30C to 50C ambient operating temperature, UL certification, and ready for wireless controls, while outputting at least 90W, the EUD-096SxxxDTA family would be best.

This family has 4 different output current models:

- EUD-096S070DTA
- EUD-096S105DTA
- EUD-096S210DTA
- EUD-096S350DTA

The best model for **Example 1** requiring 2.8A is EUD-096S350DTA. The best model for the **Example 2** requiring 1.4A is EUD-096S210DTA.

Note that other driver families of higher rated power output may also be used. For example, if one luminaire design requires at least 90W and another requires at least 130W, it may be advantageous to select a 150W driver to work for both applications.

Inventronics has a dedicated technical support team ready to answer questions and provide LED driver recommendations based upon provided application information. Please contact your local sales representative if additional assistance is desired.

For additional resources on the differences between LED driver families, please visit our technical support page.

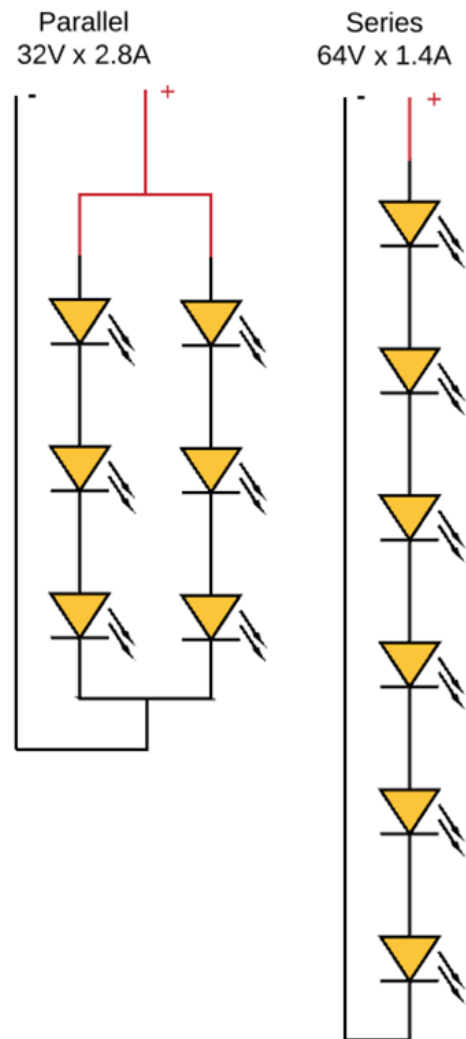

Figure 4: Example 1 in Parallel and Example 2 in Series

Understanding the I-V Operating Area of Constant Power Drivers

The programmable line of Inventronics drivers have a constant current output, but also maintain a constant power output for a specified programming range. This means that as the output current is lowered, the output power is not de-rate, but instead the maximum output voltage will rise. This behavior is described in the I-V Operating Area for each model number and **Figure 5** provides a zoomed-out view of how this information is presented in datasheets.

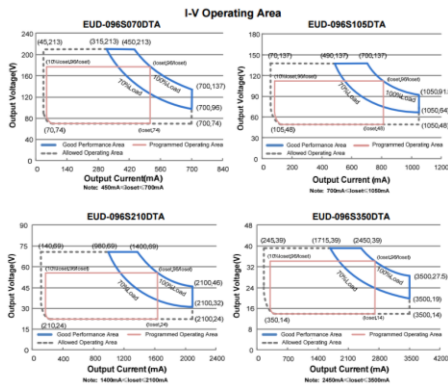

Figure 5: Specified I-V Operating Range in Datasheet

Using the EUD-096S3500DTA for example, the settable output current range where the driver can still output a full 96W is from 2.45A to 3.5A. **Figure 6** highlights this in orange.

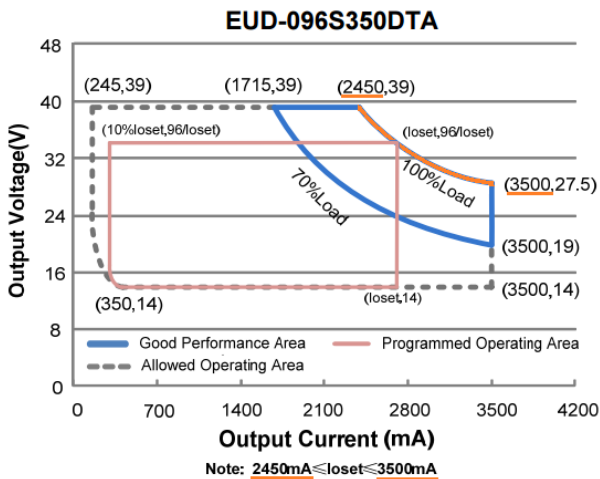

Figure 6: Full-Power Current Range

As the output current, or loset, is varied, the output voltage upper limit is also varied. **Figure 7** shows two examples of this highlighted in orange. If loset equals 3.2A, the upper voltage limit is 30V and if loset equals 2.6A, the upper voltage limit is 37V.

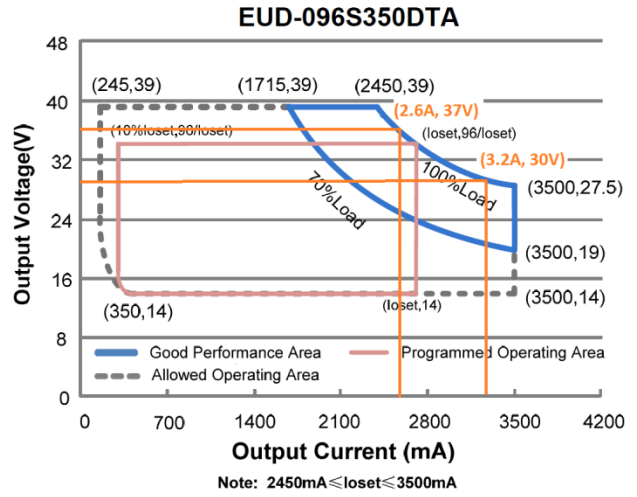

Figure 7: Upper Voltage Limit Varies Depending on loset

As the output current is lowered to less than 2.45A, the output voltage is limited to 39Vdc and the output power starts to de-rate. **Figure 8** shows the limited upper voltage rail highlighted in orange.

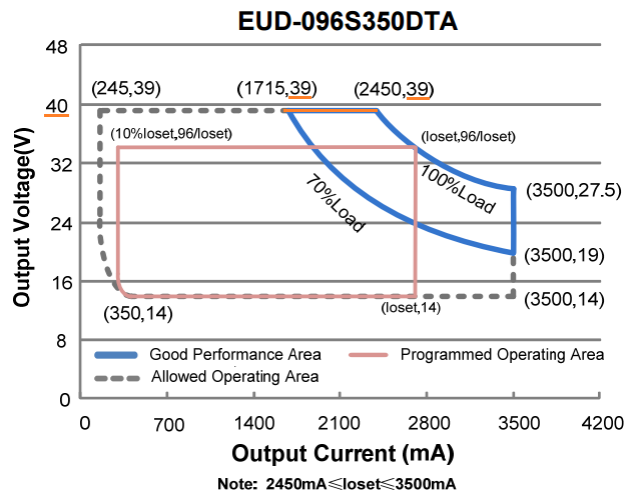

Figure 8: Output Voltage Limitation

Good Performance Area

For every programmed, or set, output current (I_oset), there is a minimum and maximum output voltage specified for optimized THD, PF, and efficiency performance. This is defined in the datasheet within the blue portion called the “Good Performance Area” and is highlighted in orange in **Figure 9**. Notice the I_oset and V_out values are provided for each corner of the curve.

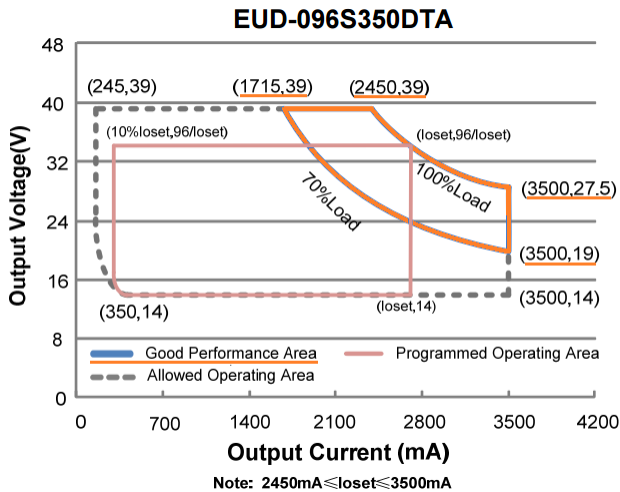

Figure 9: Optimized “Good” Performance Area

The minimum load, or minimum voltage limit, for “good” performance is specified in the curve as 70% of the maximum load. With this information and rearranging the equation for power:

$$P = I \times V$$

The minimum and maximum output voltage for any given I_oset can be determined using the following equations:

$$V_{fmax} = P_{rated} \div I_{o\text{set}}$$

$$V_{fmin} = (P_{rated} \div I_{o\text{set}}) \times \%load$$

For example, when I_oset is 2.45A, the resulting output voltage range is:

$$96W \div 2.45A = 39.2V_{dc}$$

$$(96W \div 2.45A) \times 70\% = 27.4V_{dc}$$

Table 1 provides the output voltage range specified for good performance. Notice that as I_oset is less than 2.45A, V_{max} is limited to 39V and the maximum power output is de-rated to less than 96W.

Table 1: Output Voltage Range for Various I_oset Points

I _o set (mA)	V _{min} (Vdc)	V _{max} (Vdc)	P _{outmax} (W)
3500	19.2	27.4	96.0
3200	21.0	30.0	96.0
2800	24.0	34.3	96.0
2450	27.4	39.0	96.0
2400	28.0	39.0	93.6
2100	32.0	39.0	81.9
1750	38.4	39.0	68.3

Allowed and Programmed Operating Area

It is best practice to set the output current and choose a load within the good performance area; however, there may be occurrences where the driver is required to perform outside this area. **Figure 10** shows the *Allowed Operating Area* highlighted in orange. When operating within this area, the I_oset will still be regulated within the allowed tolerance (typically +/- 5%), but THD, PF, and efficiency may be affected. In these scenarios, drivers should be tested with an actual load to determine if the driver performance is acceptable for the application.

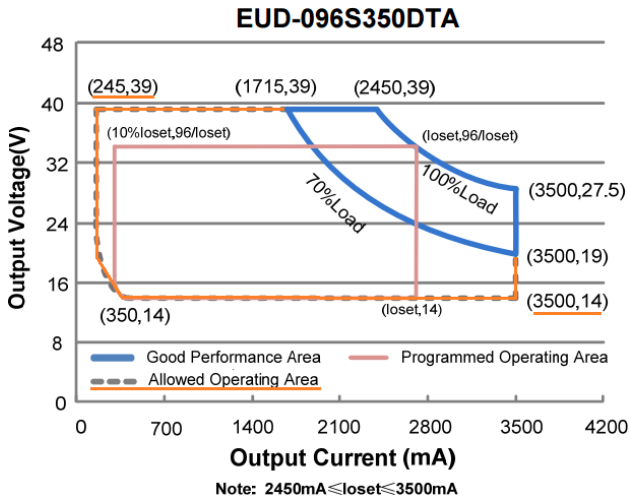

Figure 10: Allowed Operating Area

The specified *Output Voltage Range* found in the datasheet as shown in **Table 2** specifies the full possible output range depicted in the allowed operation region. Note that this full range is not true for every *I_{lose}* value (as previously shown in **Table 1**).

Table 2: Datasheet Model Number Specifications

Adjustable Output Current Range	Full-Power Current Range(1)	Default Output Current	Output Voltage Range	Max. Output Power
245-3500mA	2450-3500mA	2800 mA	14 ~ 39Vdc	96 W

The *Programmed Operating Area* describes the maximum voltage and minimum dimming output current for the given *I_{lose}*. Notice the minimum

dimming output is 10% of *I_{lose}* when *I_{lose}* is greater than the minimum *I_{lose}* specified for full-power; otherwise, it is fixed to 10% of the minimum *I_{lose}* specified for full-power. Still using EUD-096S350DTA as example, this behavior is highlighted in **Figure 11**.

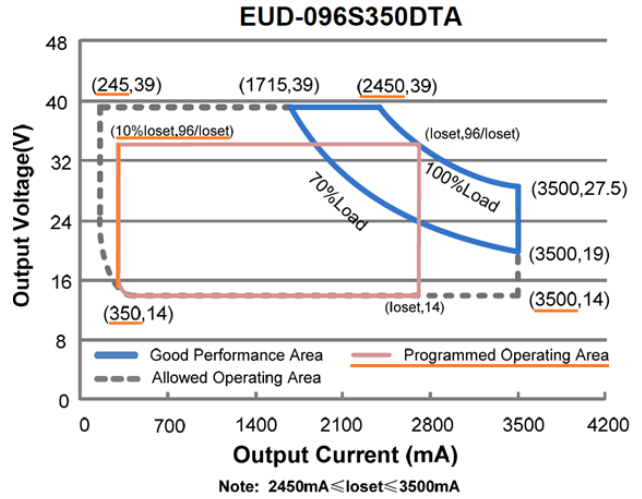

Figure 11: Minimum Dimming Output

Table 3: Minimum Dimmed Output Varies Depending on *I_{lose}*

<i>I_{lose}</i> /Maximum Output Current	Minimum Dimmed Output Current
3500mA	350mA
2800mA	280mA
2450mA	245mA
1715mA	245mA
1400mA	245mA

Programming

To take advantage of the various programmable features, download the device driver and the programming interface from the Inventronics website at the following link: <https://www.chinaleddriver.com/resources/software/>

- 'PRG-MUL2 Device Driver (Install First)'
- 'Inventronics Multi-Programmer'

Note: The interface is only supported on Microsoft systems and the 'Microsoft.NET Framework 4.0' version or above is required for operation.

For more detailed information about downloading the software interface or about the devices required and accessories available for programming, please visit our *technical support page*.

Connections for Programming

The input and output cabling will vary depending on the region the driver is intended to be installed in, but the connections for programming are the same for all 0-10V, PWM, and Timer dimming capable drivers.

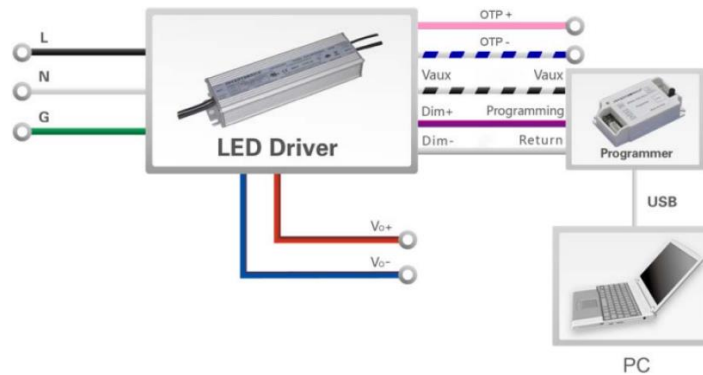

Figure 12: Programming Connections for Driver Ending in -DTA

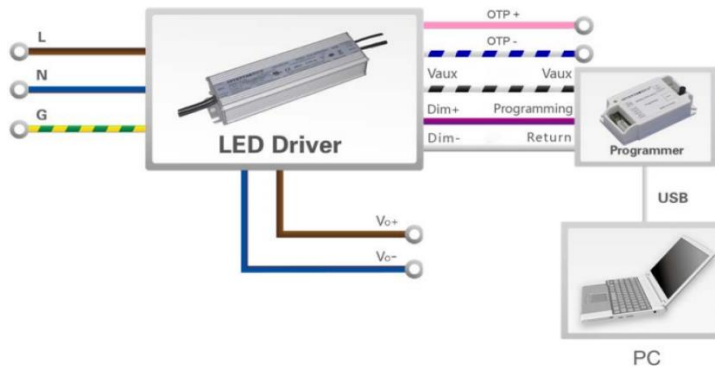

Figure 13: Programming Connections for Driver Ending in -DVA

*Note that AC power is not required for programming. As shown in Figure 12 and Figure 13, wires should be left floating if not connected to the programmer.

Opening the Inventronics Software Interface

After opening the *Inventronics Multi Programmer* software, a pop-up window for user account control may appear and ask for permission to allow the program to “make changes to your device”. If this happens, select “Yes” and **Figure 14** will appear. Select the “0-10V dimming driver” option and then click “Startup”.



Figure 14: Selection Menu for Product to be Programmed

The *0-10V Dimming Driver Configuration* window will appear after testing if the programmer supports offline programming. (The PRG-MUL2 supports this function.) This window is shown in **Figure 15**.

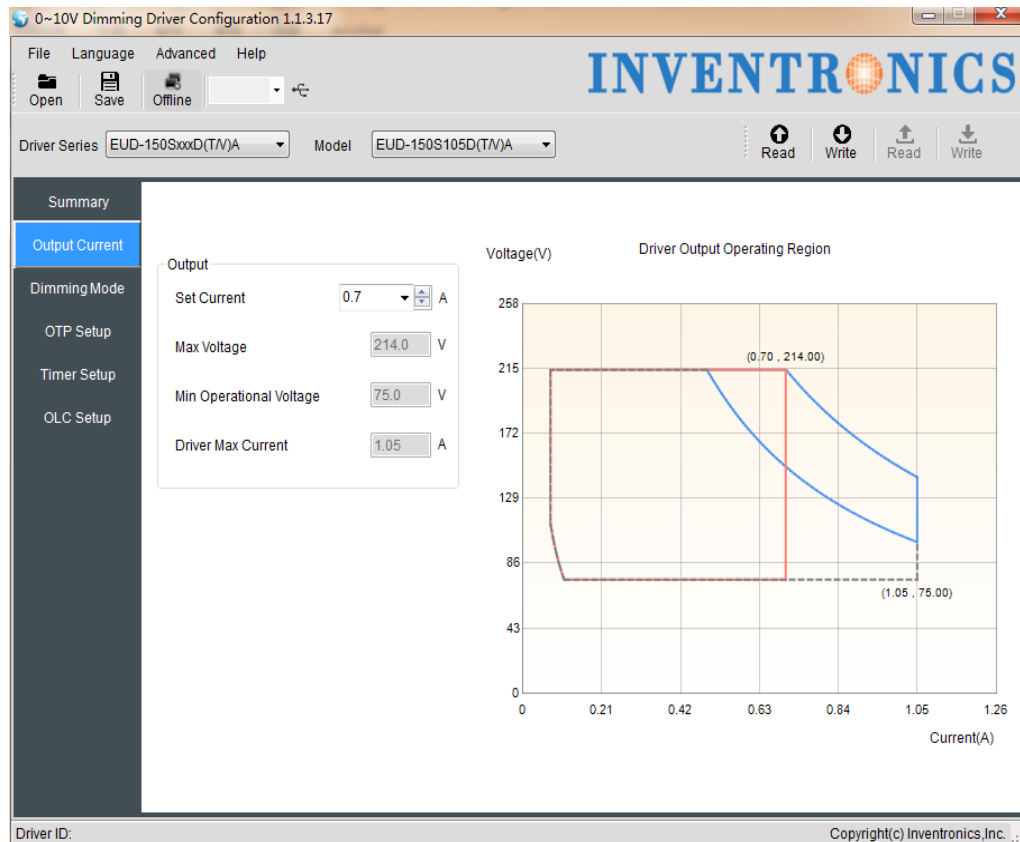

Figure 15: 0-10V Dimming Driver Configuration Window

Changing the Output Current and Resulting Optimized Output Voltage Range

Every programmable driver has a default output current that is specified in the datasheet. This is chosen based upon common output currents used, but can easily be changed through the programming software interface.

Under *Select LED Driver*, the drop-down menus for both *Series* and *Model* should be selected according to the model being programmed, see **Figure 16** and **Figure 17**. If the LED driver is connected, the “Read Driver” button may also be selected to autofill these drop-downs.

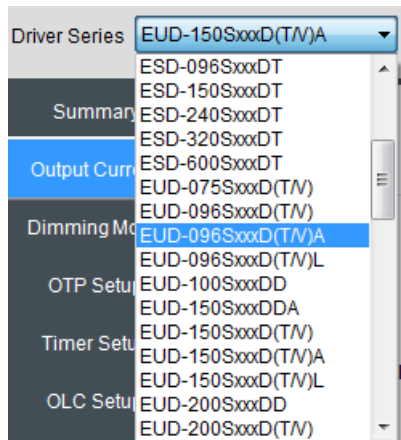

Figure 16: Select Series

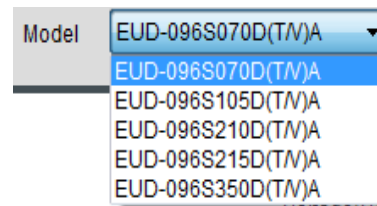

Figure 17: Select Model

Using the EUD-096S210DTA driver as an example, notice the maximum programmable output current for this driver is 2.1A as shown in **Figure 18**. (This also happens to be the default output of the driver, but this is not true for every model number. The datasheet should always be referenced for the correct default output current.) The optimized output voltage range for this *I_{oset}* is 28Vdc to 46Vdc (60% load to 100% load).

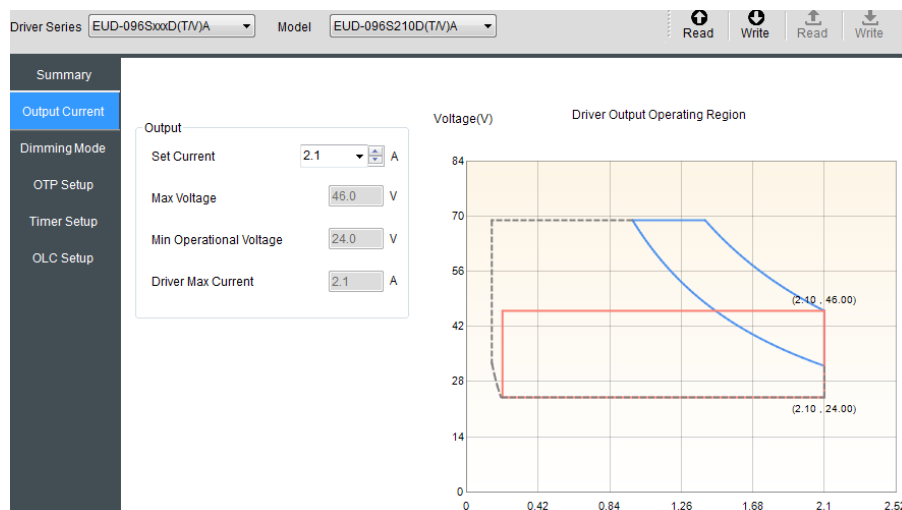

Figure 18: Software Interface Default Current Setting

In **Example 2**, the output characteristics were defined as 64Vdc and 1.4A. The EUD-096S210DT Ioset can be programmed to 1.4A, resulting in an optimized output voltage range of 42Vdc to 69Vdc. This is shown in **Figure 19**.

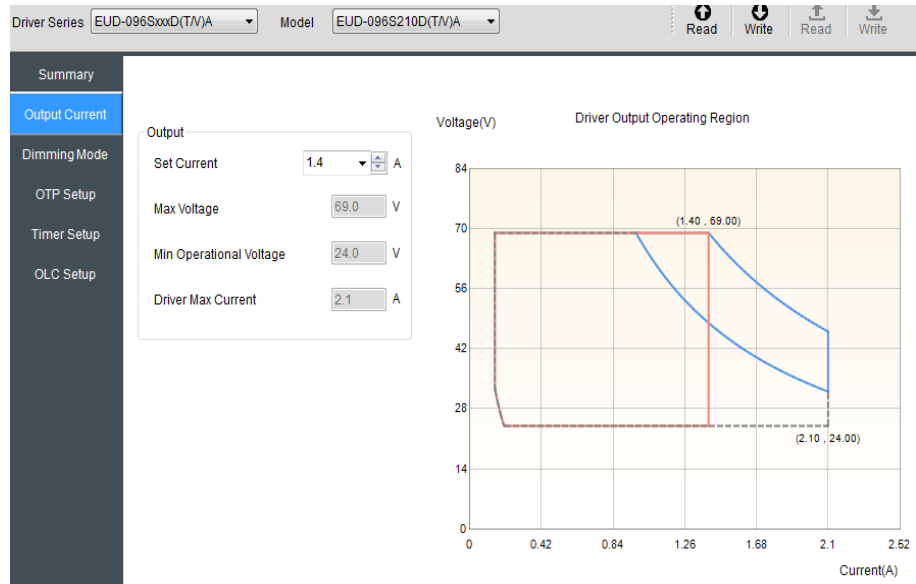

Figure 19: Change Output Current

Selectable Dimming Methods

Different series drivers offer different dimming methods. This includes 0~10V, 0~5V, PWM, and timer dimming options as well as the option to enable output lumen compensation.

0~10V and 0~5V Dimming

The default for all drivers discussed in this guide is *0~10V Logic* as shown in **Figure 20**. Some drivers also offer 0~5V Logic which has the same functionality, but reduces the overall dimming signal range.

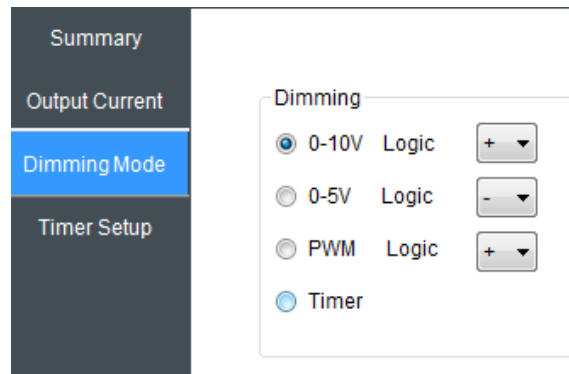

Figure 20: Default 0~10V Dimming

The wiring diagram and 0-10V dimming curve for the driver may be found in the datasheet as shown in **Figure 21**. The depicted “dimmer” can be replaced with any 0-10V signal and this curve shows that the driver dims down to 10% and then dims-to-off around 0.6V.

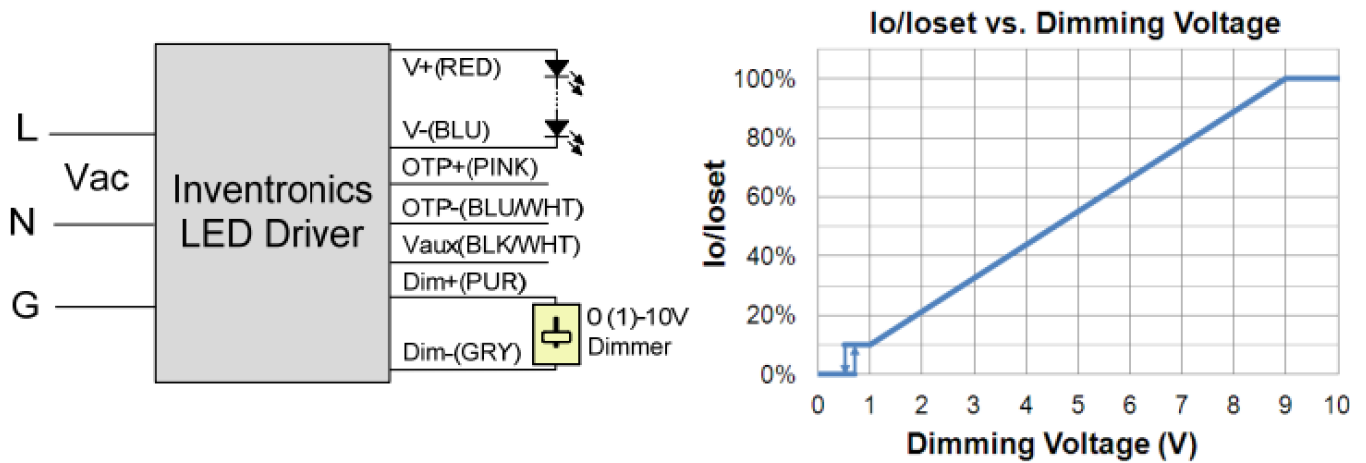

Figure 21: 0-10V Wiring and Dimming Curve

*Note that the dimming performance for every driver, with minimum dimming levels being 10%, 5%, or 1%, will be specified in this curve as well as under the *Dimming Specifications* section in every datasheet.

PWM Dimming

Pulse Width Modulation can also be used to realize dimming with both positive and negative logic as shown in **Figure 22**.

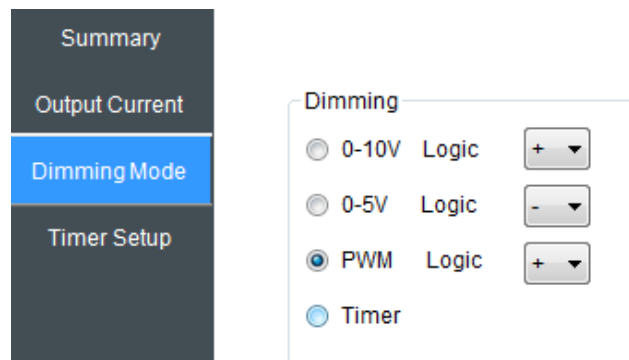

Figure 22: Selecting PWM Dimming

Like the 0-10V dimming, the datasheet includes curves to show the dimming performance given a PWM signal. This is shown in **Figure 23**.

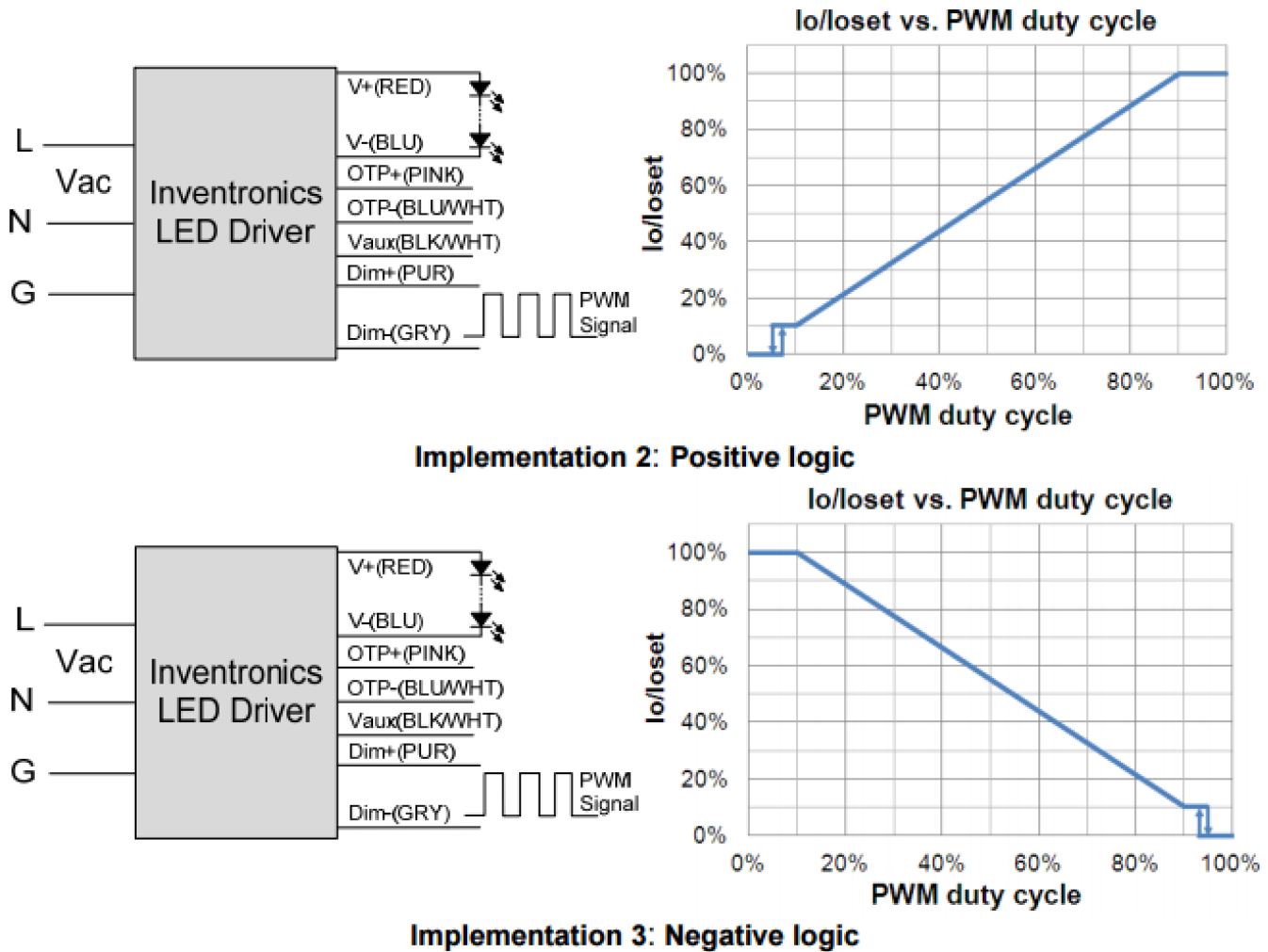

Figure 23: PWM Wiring and Dimming Curve for Positive and Negative Logic

The datasheet’s *Dimming Specifications* section provides more information related to the PWM signal requirements, as shown in **Figure 24**.

PWM_in High Level	3 V	-	10 V
PWM_in Low Level	-0.3 V	-	0.6 V
PWM_in Frequency Range	200 Hz	-	3 KHz
PWM_in Duty Cycle	1%	-	99%
PWM Dimming off (Positive Logic)	2%	5%	8%
PWM Dimming on (Positive Logic)	4%	7%	10%
PWM Dimming off (Negative Logic)	92%	95%	98%
PWM Dimming on (Negative Logic)	90%	93%	96%
Hysteresis	-	2%	-

Figure 24: PWM Datasheet Specifications

Timer Dimming Modes

Various applications may need to dim based upon the duration of operation. Some models offer only the Traditional-Timer and others offer this in addition to the *Self Adapt-Midnight* timer as well as the *Self Adapt-Percentage* timer. By selecting the *Timer* method as shown in **Figure 25**, the *Timing Setting* tab is highlighted and able to be adjusted.

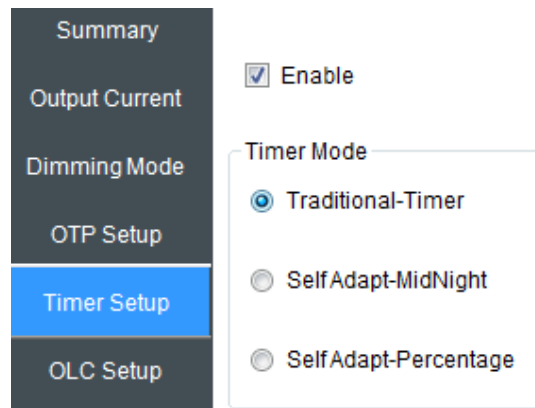

Figure 25: Select Timer Dimming Modes

Traditional-Timer

The *Traditional-Timer* function is the default under the timer dimming modes and allows a curve to be set following the amount of time the driver has been ON. With this, the feature is not a real-time clock, but functions instead as a counter. Referencing **Figure 26**, the “0” on the x-axis corresponds to when the driver has AC power applied and then counts to 19 hours. If the driver is ON for more than 19 hours, the dimming level set at the 19-hour point will continue to be held until the driver is power cycled. The curve can be set to include up to six different dimming stages where the dimming level, hold time, and fade time are all adjustable.

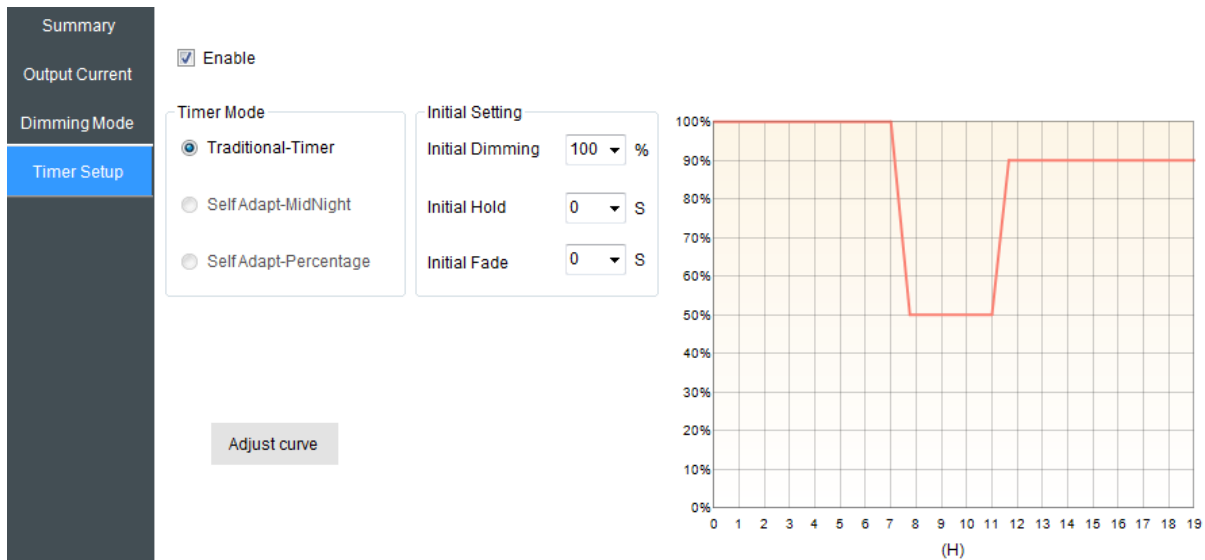

Figure 26: Traditional-Timer

Self Adapt-MidNight

The *Self Adapt-MidNight* feature is similar to the *Traditional-Timer*, but it averages the total ON time of the past two days and sets the midpoint, or “MidNight”, of the curve to correlate with half of the average ON time. This may be especially useful for applications where seasonal changes drastically affect the required ON time for the driver.

Referencing **Figure 27**, the red curve sets the total possible dimming performance and the purple curve reflects the actual timer performance based upon the averaged ON time. **Figure 27**, shows the actual ON time as 14 hours, with the *MidNight* set 7 hours after operation.

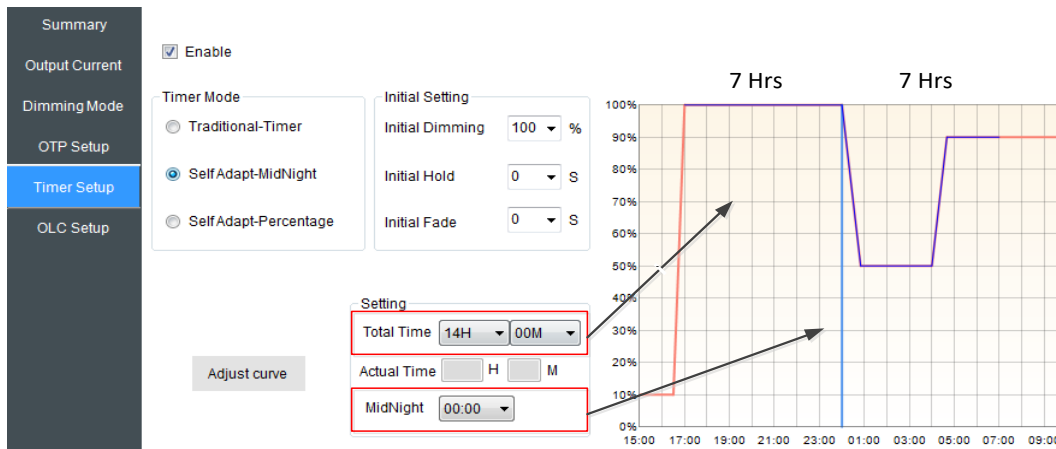

Figure 27: Self Adapt-MidNight 14 Hours ON

If the average were to shift to 10 hours ON, there would be 5 hours of operation before and after the *MidNight* line as shown in **Figure 28**. If the average changed to 16 hours, the actual performance would extend and follow the red curve with 8 hours of operation before and after the *MidNight* setting. When using the *Self Adapt-MidNight* mode, the curve is either extended or trimmed.

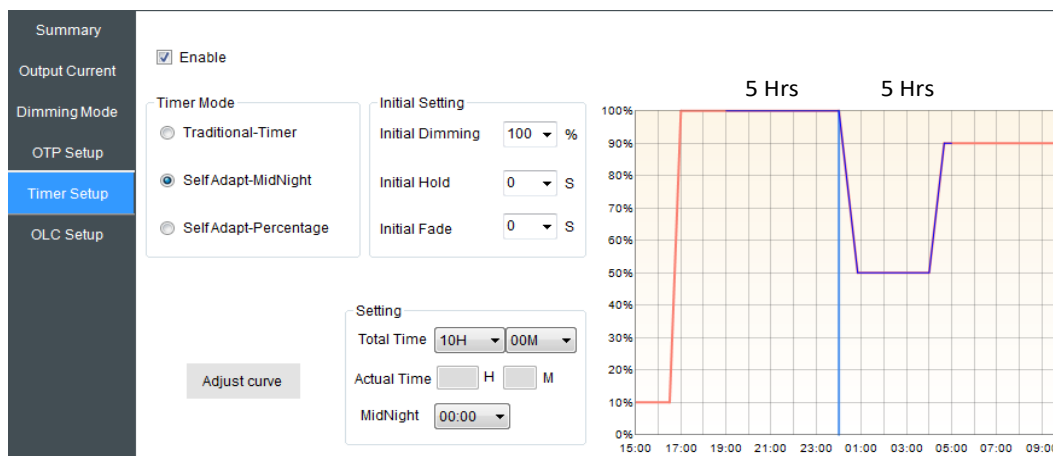

Figure 28: Self Adapt-MidNight 10 Hours ON

*Note that ON durations will only be calculated as part of the average if the ON time is greater than 5 hours. This helps to avoid faulty averages during abnormal ON events. Also, the average will only be changed if there is a difference less than 15 minutes between two days.

Self Adapt-Percentage

This is similar to the *Self Adapt-MidNight* in that the curve adjusts depending on the average ON time calculated by the driver. The difference is that instead of extending or trimming the performance curve, the curve adjusts as a percentage of the total ON time. With this, each specified dimming stage in the curve will be realized, but the total duration for each dimming stage will vary. **Figure 29** shows a curve with an average ON time of 14 hours. The first dimming stage accounts for 30% of the curve with a duration of 4.2H, the second dimming stage accounts for 40% of the curve with a duration of 5.6H, and the last dimming stage accounts for the last 30% of the curve with a duration of 4.2H.

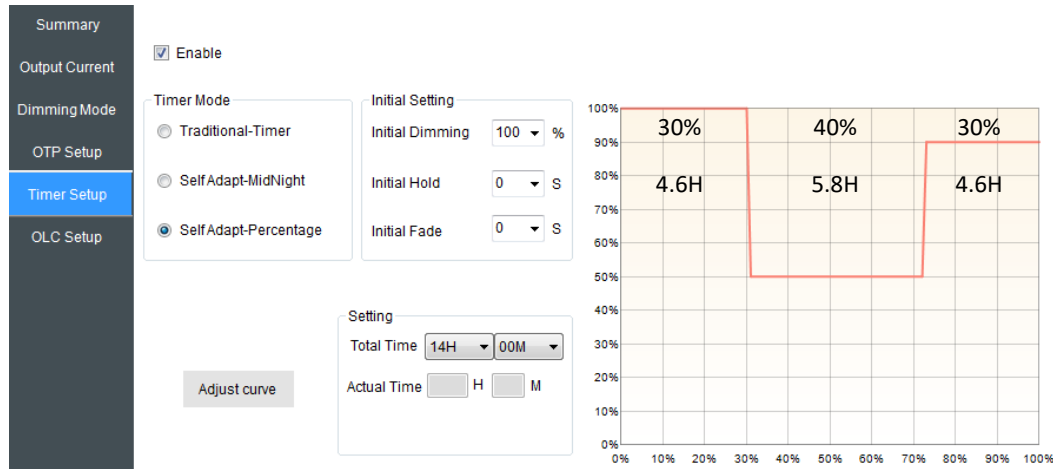

Figure 29: Self Adapt-Percentage 14 Hours ON

To compare, **Figure 30** shows the same curve with an average ON time of 10 hours. The first dimming stage accounts for 30% of the curve with a duration of 3H, the second dimming stage accounts for 40% of the curve with a duration of 4H, and the last dimming stage accounts for the last 30% of the curve with a duration of 3H.

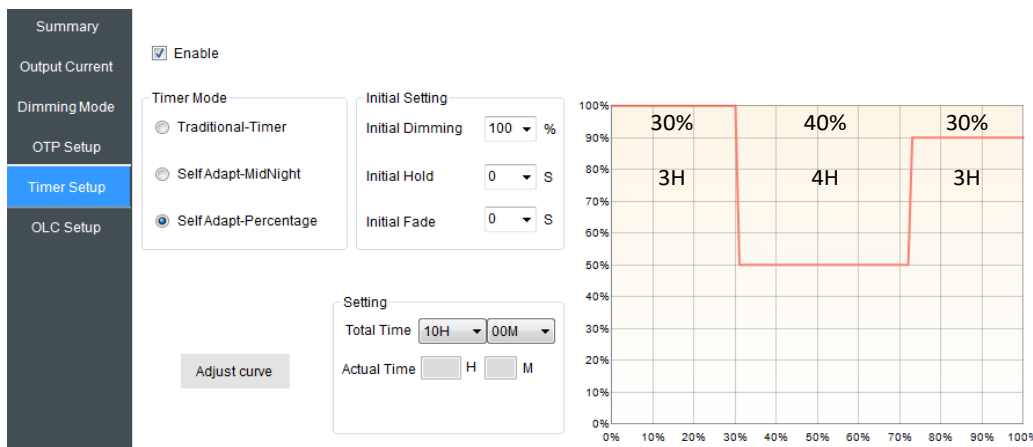

Figure 30: Self Adapt-Percentage 10 Hours ON

*Note that same as *Self Adapt-MidNight*, ON durations will only be calculated as part of the average if the ON time is greater than 5 hours. This helps to avoid faulty averages during abnormal ON events. Also, the average will only be changed if there is a difference less than 15 minutes between days.

Output Lumen Compensation

In addition to all dimming methods, *Output Lumen Compensation* can also be enabled. This feature helps counter anticipated decreases in the luminous efficacy of LED modules to maintain a uniform light output over time. The reduction of light output over time for a traditional design is depicted in **Figure 31**.

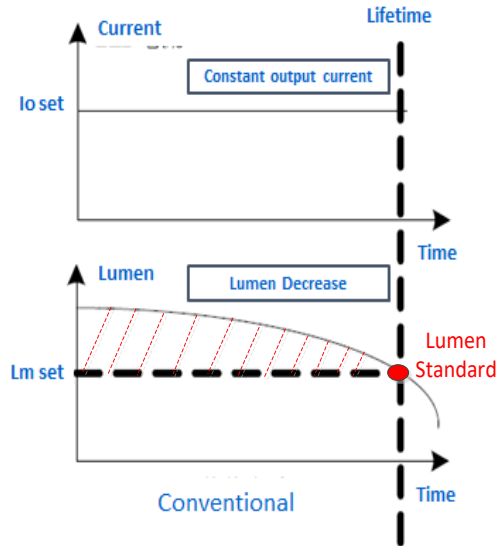

Figure 31: Decrease in Lumen Output Over Time for Traditional Designs

Using the software interface as shown in **Figure 32**, 16 different dimming stages may be set according to expected lumen depreciation. The loset percentages and the desired runtime transitions between dimming stages are all configurable by typing values into the field. The total allowable programmed time is 64kH, but is not shown as a default.

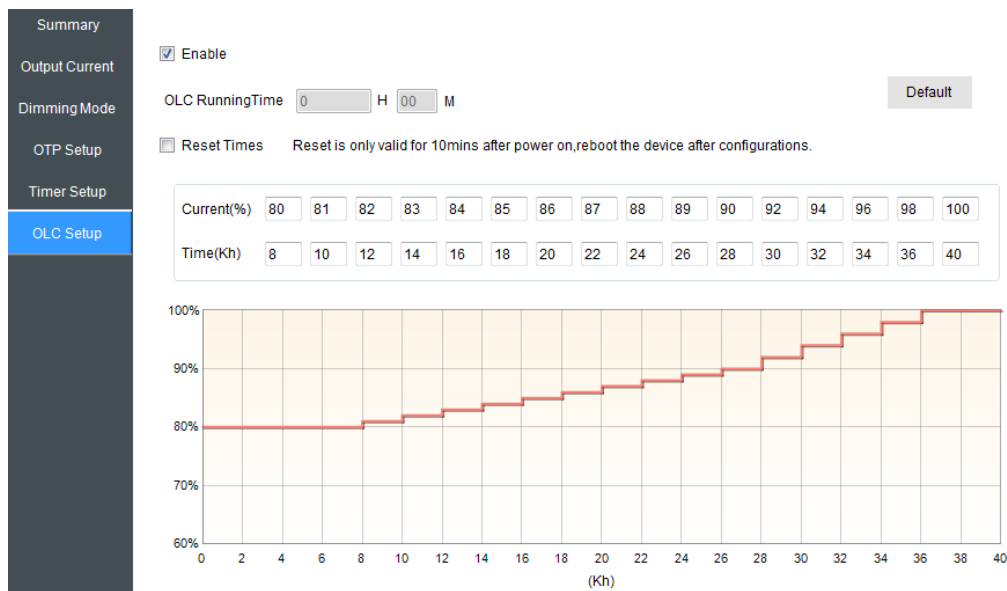

Figure 32: Output Lumen Compensation Setting

Using this feature, constant lumen output over time may be achieved as described in **Figure 33**.

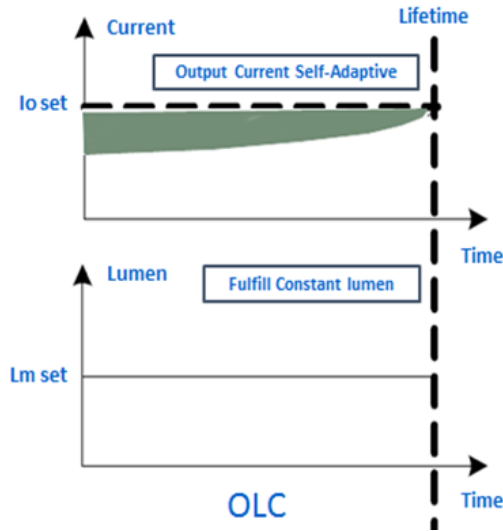

Figure 33: Enable OLC for Consistent Lumen Output Over Time

Implementing Over Temperature Protection (OTP)

External Over Temperature Protection (OTP) is featured in all newer, full featured series. This built-in feature provides an additional mode of protection for either the LED modules, the LED driver, or any other temperature sensitive component within a luminaire design. A NTC thermistor may be implemented to utilize this protection mode, with wiring shown in Figure 34. The LED driver monitors the resistance of the NTC thermistor and if it reaches a predefined trigger value, the output current will de-rate to a predefined percentage of $I_{o\text{set}}$, allowing the system to cool. As the system cools the output current will gradually increase until it is back to 100% $I_{o\text{set}}$. It will reach 100% $I_{o\text{set}}$ at the predefined recovery resistance.



Figure 34: Adding NTC Thermistor for External OTP

The OTP trigger and recovery points are adjustable within the software interface, providing the flexibility to use most any NTC. With this, the points can be set to correspond with any desired temperature as specified within the NTC performance curves. **Figure 35** shows each adjustable parameter which can be changed via the slide bar or by typing a resistance value.

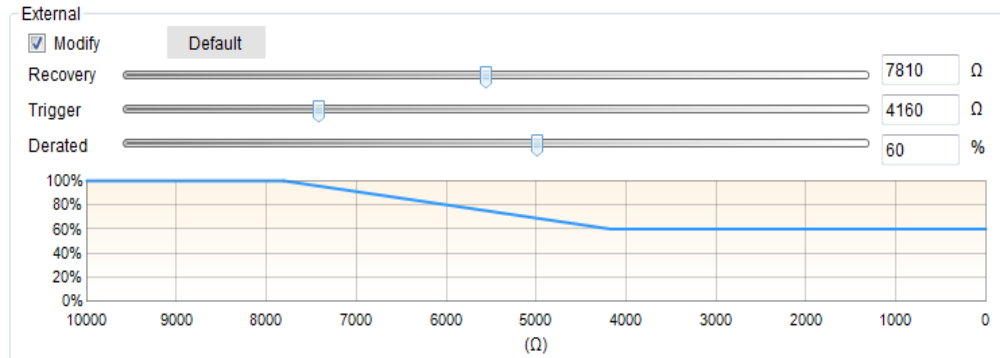

Figure 35: External OTP Setting

New programming interface adds an adjustable function for internal over temperature protection for some of drivers. The protection triggered temperature, recovery temperature and current derated value can be pre-set in programming interface, please refers to **Figure 36**.

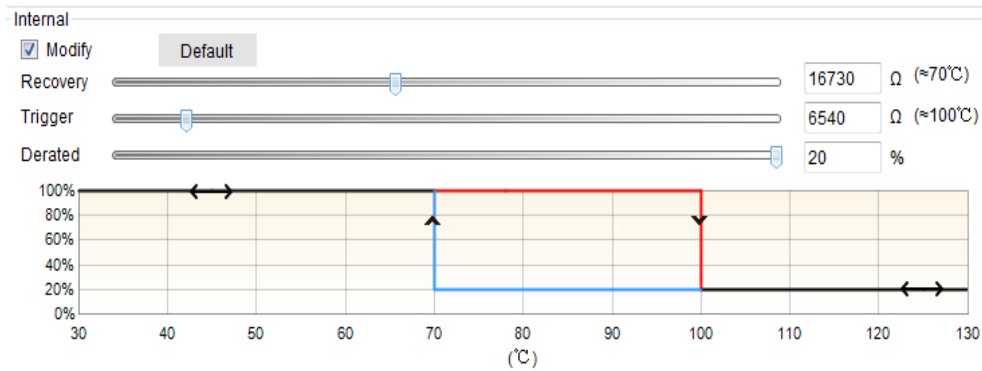

Figure 36: Internal OTP Setting

Writing to Driver and Saving Configuration Files

After adjusting the programmable features to best suit a given application, all settings are then defined as a single configuration file. To program the configuration file into the driver, the “Write to Driver” button should be clicked and a window will appear saying that the programming was successful. If wanting to see the last configuration file programmed into a driver, the “Read Driver” button should be clicked and all fields will auto-populate with that configuration file’s settings. If the setting will need to be referenced in the future, the “Write CFG” button may be used to save the configuration as a .ini file for later use. The “Read CFG” button will later be used to open any saved configuration files for programming the driver.

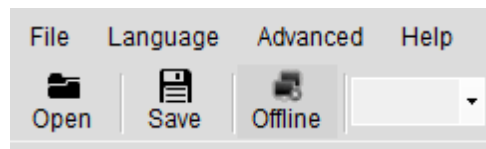

Figure 37: Saving and Writing Configuration Files to Program Drivers

*Note that configuration files can also be saved within the programmer and used without a computer for offline programming. For more information about offline programming, please visit our technical resources page.

Disclaimer

All contents shown in this design-in guide had been verified and analyzed by INVENTRONICS, the document is only for reference as designing INVENTRONICS' products in whole LED fixture. INVENTRONICS doesn't have the responsibility and liability for any damages and faults when relying on the contents of this document.

Please regularly update new version and have related sales involved in for specific design in of projects.

Product and Product information in the Design in Guide are subject to change without notice

Version 1.2