

Dimming Control Circuit Application Note

The purpose of this application note is to highlight the upcoming UL amendment taking effect May 1, 2020 and to provide related installation instructions.

Standard Requirement & Exceptions

According to the upcoming requirement from Supplement SF, UL8750 (V2) and chapter 15.4, IEC 61347-1-2015, LED drivers shall provide suitable insulation between input and output circuits as well as between output and dimming control circuits. Though isolated dimming is required, exceptions are called out in both standards where all conditions must be true:

SF Part of UL 8750

- The control circuit does not exit the lighting equipment (i.e. the control circuit is internal to a fire/electrical enclosure).
- Risks of fire and shock concerns due to interposed circuits between different components of the lighting equipment are addressed by circuit analysis, component abnormal tests, or both.
- The required isolation for Isolated, Class 2, or LVLE power circuits is not compromised.
- The control circuit is marked per SF8.4, and

15.4 Part of IEC 61347-1

- control signals are injected via the supply terminals or circuits connected to the supply via a separate terminal;
- control signal receiver is located in the ballast case and the signal is transmitted remotely via infra-red or radio wave transmitters;
- control terminals are only to be used together with one sensing device outside of the controlgear case, but inside the luminaire (not remotely).

Installation Instructions for Non-Isolated Dimming Drivers

To summarize the exceptions outlined above, non-isolated dimming drivers are suitable for use inside an enclosure where the dimming leads do not exit the luminaire. This supports designs where the dimming leads are capped off and not in use, or where wireless converters or sensors are used, as shown in Figures 1 and 2:

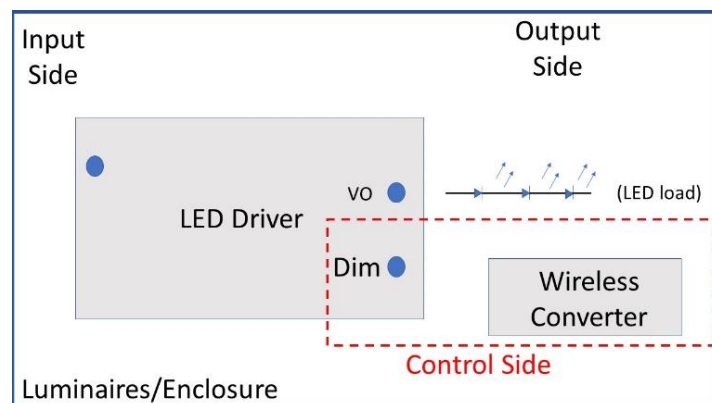

Figure 1: Wireless Converter Connection (Ex: Synapse, Zigbee, Bluetooth, Wifi, etc)

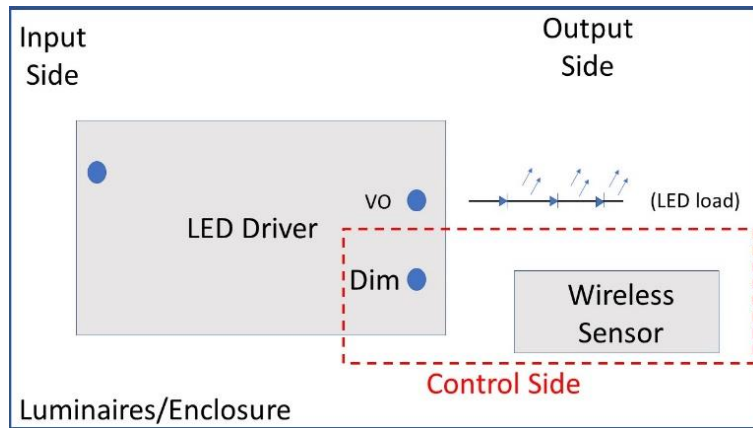

Figure 2: Wireless Sensor Connection (Ex: Occupancy, Photocell, etc)

Note that other workarounds *may* be identified, but this requires a detailed, system level review with your certification body. With these exceptions, the isolated dimming requirement is application dependent, allowing LED driver manufacturers to continue marketing and producing non-isolated dimming drivers.

Non-Isolated Dimming Drivers

Inventronics' most common non-isolated dimming series are shown in the Table 1 below:

EBC + EBD + EBS	EUC	EUD + EUG + EUR	ESC + ESD + ETC	LUC + LUD + LTC
EBC-042SmDV	EUC-025SmDS	EUD-075SmDX	ESC-075SmDT	LUC-009SmDSF
EBC-060SmDV	EUC-026SmDS	EUD-096SmDXA	ESC-150SmDT	LUC-018SmDSF
EBC-420SmDV	EUC-035SmDX	EUD-096SmDX	ESD-096SmDT	LUC-018SmDSP
EBD-075SmDV	EUC-036SmDX	EUD-150SmDD	ESD-150SmDT	LUC-018SmDSW
EBD-100SmDV	EUC-042SmDS	EUD-150SmDXA	ESD-240SmDT	LUC-024SmDSP
EBD-150SmDV	EUC-050SmDX	EUD-150SmDX	ESD-320SmDT	LUC-024SmDSW
EBD-200SmDV	EUC-052SmDX	EUD-200SmDD	ESD-600SmDT	LUC-026SmDSF
EBD-240SmDV	EUC-075SmDX	EUD-200SmDXA	ETC-150SmDT	LUC-040SmDSF
EBD-255SmDV	EUC-085SmDX	EUD-200SmDX		LUC-042DmDDM
EBS-040SmDTE	EUC-096SmDX	EUD-240SmDXA		LUC-042SmDSP
EBS-080SmDTE	EUC-100SmDX	EUD-240SmDX		LUC-048SmDSP
EBS-120SmDTE	EUC-108TmDX	EUD-320SmDX		LUC-060SmDSF
EBS-160SmDTE	EUC-120SmDX	EUG-075SmDX		LUC-066TmDXM
	EUC-120TmDX	EUG-096SmDX		LUC-072QmDXM
	EUC-144QmDX	EUG-150SmDX		LUD-040SmDSF
	EUC-150SmDX	EUG-200SmDX		LUD-060SmDS2
	EUC-160QmDX	EUG-240SmDX		LUD-060SmDSF
	EUC-180PmDX	EUR-096SmDX		LTC-040SmDSP
	EUC-200PmDX	EUR-150SmDX		
	EUC-200SmDX	EUR-200SmDX		
	EUC-320SmDX	EUR-240SmDX		

*X= V or T *X= V or T

Table 1: Inventronics most common non-isolated dimming series

Only 0-10V dimmable drivers were made without isolation in the past. All recent and future Inventronics designs will include added isolation between the output and dimming circuit.

Table 1 above shows the base part number. Any derivative from the base model with an added “-xxxx” still will not have isolated dimming. [Visit chinaledriver.com FAQ webpage](#) for more information about the part numbering scheme.

Pairing Non-Isolated and Isolated Dimming Drivers to the Right Controllers

Non-isolated dimming circuits share the same rating as the driver output (SELV/Non SELV/ Class2 or LVLE). With this, any external controls connected to the dimming circuit must be suitable for corresponding (SELV / Non SELV / Class 2 or LVLE) connections.

CAUTION: More than one power supply present when dimming circuit is intended for connection to an external supply (other than Class 2).

MISE EN GARDE : Plus d'une alimentation présente lorsque le circuit de gradation est destiné à être raccordement à une alimentation externe (autre que la classe 2).

Isolated dimming circuits hold their own rating separate from the driver output (SELV / FELV / Class 2 or LVLE). Similarly, the external control must be suitable for corresponding (SELV / FELV / Class 2 or LVLE) connections.

Additional Resources:

For electrical parameters, features and all wiring diagrams, please refer to the product datasheet or [contact your technical support representative](#) for assistance.

For questions related to your design's compliance with the safety standards outlined above, please consult your certification body. For further information regarding the changes to UL 8750 taking effect Dec 2,2021

Disclaimer

This note is for reference only. It is the responsibility of the customer to thoroughly analyze all aspects of the customers' proposed application for the products. The customer is solely responsible for making the final selection of the product(s) to be used and to assure that all performance and safety requirements of the application are satisfied. Inventronics makes no representation or warranty as to the completeness or accuracy of the information contained herein. The products and specifications set forth in this document are subject to change without notice and Inventronics disclaims any and all liability for such changes.